



RHZK Series

Self-contained Positive Pressure Air Breathing Apparatus

OPERATING MANUAL



Catalogs

1	Safety norm	1
1.1	Correct use	1
1.2	Responsibility information	2
1.3	Safety and preventive measures	3
1.4	Cloud Service Statement	5
1.5	unit conversion	5
1.6	Contact information	5
2	Summary	6
2.1	Backplate assembly	9
2.2	Full-face mask	24
2.3	Electronic pressure gauge (optional)	28
2.4	Mechanical pressure gauge (optional)	28
3	Appearance test	28
3.1	Air bottle	29
4	Functional test	31
4.1	Check the sealing ability of the pressure reducer	31
4.2	Pressure check	32
4.3	Air cylinder harness tightening check	32
4.4	Low air pressure alarm check	33
4.5	Check the full-face mask and the air supply valve function	33
4.6	Electronic equipment inspection	34
5	Adorn	34
5.1	Prepare	35
5.2	Wear SCBA	36
5.3	Wear a mask	37
5.4	Install the air supply valve and check the breathing performance of the air pager	38
6	Termination of use	43
6.1	Remove face cover	43
6.2	Discharge back gear	45
6.3	Replacement of cylinder	46
7	Tempus utile	49
7.1	Freezing environment use	50
8	Maintenance overhaul	51
8.1	Clean, disinfect, and dry	52
8.2	Maintenance of the full cover	53
8.3	Maintenance of the air supply valve	53
8.4	Maintenance of the compressed air bottles	55
8.5	SCBA maintenance and maintenance	55
	Appendix:	58
	Packing list	58
	Order number	58
	Name of a part	58
	Unit	58
	Quantity	58
	Spare parts bag parts table	58
	Check the records form regularly	59

1 Safety norm

1.1 Correct use

RHZK series of self-contained positive pressure fire air breathing apparatus (SCBA) is a kind of air breathing apparatus which does not rely on the atmospheric environment. It was widely used in fire, shipbuilding, petroleum, chemical, metallurgy, electricity, mining, medical, sanitation industry, to provide reliable respiratory protection in special environment, avoid exposure to the atmosphere where has a direct harm to life or health.

SCBA is an equipment which protect the wearer from inhalation of harmful substance mixture, harmful biological agents and hypoxia phenomenon, when wearer enter the hypoxia, toxic and harmful air environment. It only protects the nose and respiratory system.

The air for breathing conforming to the GB / T 31975-2015 Compressed Air for Respiratory Protection is supplied to the user from the air compression cylinder through the pressure reducer, air supply valve and mask, and the exhaled air will be released directly into the ambient atmosphere. When SCBA is in normal use, the pressure in the mask is always higher than the external environmental pressure, which can effectively prevent the external toxic and harmful aires from entering the mask and ensure the safety of users.



Dangerous!

This is a pure air protection equipment, which is strictly prohibited for diving operations.

Applicable environment: fire site, toxic and harmful aires, steam, dust, smoke and anoxic environment.

Not applicable environment: underwater, strong acid, strong alkali and other environment.

Applicable ambient temperature -30°C - +60°C.



Warning!

The device only can be used after professional training and being fully aware of the wearable and general use of the device. Failure to follow this warning may result in serious personal injury or death.

 **Warning!**

SCBA is used to protect the safety of users in the hypoxia and harmful air environment. Users must read the contents of this operation manual carefully and use this SCBA correctly. It will function as designed only if the equipment was used and maintained in accordance with the manufacturer's instructions. Otherwise it may not play the operational effect of the design. Ignoring the tips, instructions and warnings of this operation manual and failing to conduct proper inspection and maintenance of SCBA before and after use may cause serious personal injury or death to those who rely on the safety of the equipment.

It's necessary to check the product function before use. Do not use the product if the product has the abnormal function, the product doesn't have proper maintenance / maintenance, or haven't replaced legitimate MTS spare parts.

1.2 Responsibility information

- 1) RHZK series of self-contained positive pressure fire air breathing apparatus (SCBA) is the original product of MTS (Nanjing) Safety Technology Co., LTD. (MTS), and its copyright belongs to MTS company. No unit or individual shall use or copy any part of the product without authorization.
- 2) Before purchasing and using the product, users must carefully read the relevant instructions, and strictly follow the instructions in the operation manual for the correct operation. MTS Company shall not bear any legal liability for any form of loss or damage caused by the user for failing to follow the instructions of the operation manual or due to the improper operation, and the relevant liability shall be assumed by the user himself.
- 3) The selection and use of equipment only depends on the judgment and decisions of individual operators, and MTS is not responsible for this.
- 4) If the user fails to use, keep and maintain the product according to the operation manual, or fails to dismantle, refit, repair or repair without authorization, the product liability claim and warranty promised by MTS Company will automatically fail.
- 5) MTS shall not assume any responsibility for any product failure or accident caused by force majeure factors (such as natural disasters, wars, etc.).
- 6) The contents, image data or self-test data in this operation manual are protected by the copyright law, and no unit shall copy them or disclose them to a third party without the explicit written authorization of MTS

Company. MTS reserves the right to pursue legal responsibility for unauthorized use or dissemination.

- 7) Interpretation of this operation manual belongs to MTS Company. Any doubt or dispute, the interpretation of MTS Company shall prevail.
- 8) MTS Corporation reserves the right to modify the technical specifications without prior notice. Users should regularly follow the MTS company's official website and official account to understand the latest product information and operational requirements.

1.3 Safety and preventive measures

MTS Company's SCBA meets EN 137:2006 and XF-124-2013 and the use temperature range from -30°C ~ + 60°C. If the other products used with the SCBA have different (lower or higher) temperature ranges, this must be considered accordingly. The explosion-proof category using any other equipment used with this device will also be considered. The lowest category sets the limits.

If equipment is used in explosive hazardous environments, dissipable clothing and shoes must be used with dissipable ground. When used in an explosive hazardous environment, the mask safety sling must be in direct contact with the head. Do not use protective hood for firefighters under the head safety sling.

When performing tasks, compatibility between other types of personal protective equipment must be ensured during use (e. g. clothing and helmet) and those worn (PPE, including SCBA).

This equipment shall not be used near an explosive hazardous environment that produces strong static electricity.

Do not expose the device to any substance that will or may destroy any part of the SCBA and prevent the SCBA to function as designed.



Warning!

Incorrect use of SCBA may lead to personal injury or death. It needs to be professional training before use, carefully read all the contents of this operation manual and keep it properly for reference when necessary.

**Warning!**

- MTS products shall not be disassembled into parts for connected with other products or air supply system. Only MTS-supplied spare parts are permitted for installation and servicing. MTS company will pursue its legal liability for the consequences.
- It's Strict to forbidden using damaged air cylinders and high-pressure components. If there is damage or failure to work properly, please stop using it immediately, otherwise it will cause sudden leakage of high pressure air or component rupture, causing environmental damage or personnel casualties.
- Make sure that the cylinder is filled with compressed air before use. If the cylinder was under filled, the remaining air needs to make sure that it's sufficient to maintain life safety. When the alarm sounds,it's indicating that the cylinder pressure has dropped to 55Bar \pm 5Bar, the user should evacuate the site immediately, otherwise casualties may be caused by insufficient air volume.
- The cylinder inflation must be carried out to the unit holding the cylinder filling license of the provincial market supervision administration, and MTS company shall not bear any responsibility for the consequences of all illegal inflation.
- The compressed air filled in the cylinder shall comply with GB / T 31975-2015 Technical Requirements for Compressed Air for Respiratory Protection and other applicable national regulations.
- SCBA only provides protection against the user's eyes, mouth, nose and respiratory system.
- Do not disassemble electronics or remove / replace battery in explosive air environment.
- The installation, use and maintenance of electronic devices shall be followed with the product operation manual and relevant standards,It is not limited to the following standards, The relevant provisions of GB 3836.13-2013 Explosive Environment- -Part 13: Repair, Maintenance, Repair and

Renovation of Equipment, GB / T 3836.15-2017 Explosive Environment-
-Part 15: Design, Selection and Installation of Electrical Equipment,
GB/T3836.16-2017 Explosive Environment- -Part 16: Inspection and
Maintenance of Electrical Equipment, GB 50257-2014 Code for Construction
and Acceptance of Electrical Equipment in explosive and Fire Hazardous
Environment.

- Do not alter or permanently cover any label on the SCBA and the cylinder assembly.
- Check the product and do regular maintenance and daily maintenance according to the operation manual.
- Strictly follow the handling operation guide to prevent muscle strain and smash injury.

1.4 Cloud Service Statement

If the products you buy enjoy our cloud service, please know the effective time of the cloud service. After the expiration date, the service will be automatically terminated. If you need to continue to use it, please contact us in time for renewal.

Thank you for your trust and support to our company.

1.5 unit conversion

Conversion relationship: 1 MPa equals 10 Bar.

1.6 Contact information

If product problems arise, contact your local MTS authorized repair center or dealer who will provide MTS with the necessary information to resolve the problem. To return any serious questions or ask about the product, contact MTS aftermarket.

The MTS customer service hotline: **4008-479-119**

MTS Website: www.mtssafety.net

2 Summary

RHZK Series of self-contained Positive Pressure Air Breathing Apparatus (hereinafter referred to as SCBA) is a kind of personal protective equipment which can be used independently of the atmospheric environment, widely used in fire, chemical industry, ship, petroleum, metallurgy, mining, transportation, and other departments, to avoid a direct harm to life or health from smoke and air in the atmosphere or hypoxia environment for firefighters or professionally trained personnel when they engaged in fire fighting, disaster relief and rescue work.

The compressed air in the compressed cylinder is compressed through the primary reducer, and then after the secondary decompression through the air supply valve, the breathing air is supplied to the user wearing the full-face mask. The air exhaled by the user will be directly released into the ambient atmosphere.

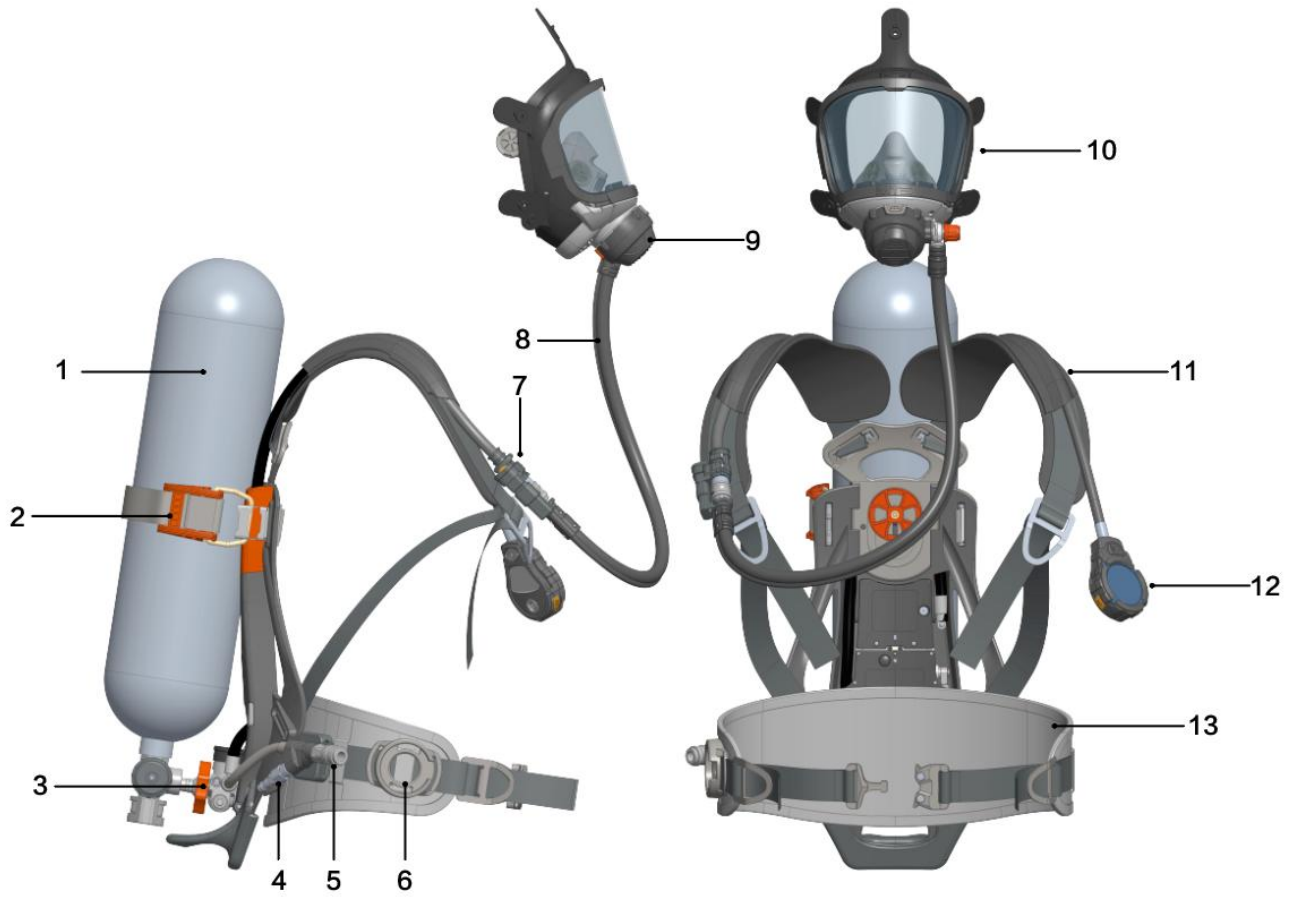

- | | |
|---|---|
| 1. Air cylinder assembly | 8. Medium pressure tube |
| 2. Cylinder strap and buckle | 9. Air supply valve |
| 3. Pressure reducer | 10. Full face mask assembly |
| 4. Medium pressure air supply interface | 11. Shoulder strap |
| 5. Other rescue interface | 12. Pressure gauge (electronic pressure gauge, electronic and mechanical pressure gauge or mechanical pressure gauge) |
| 6. Air supply valve base | 13. Waist strap |
| 7. One-touch alarm | |

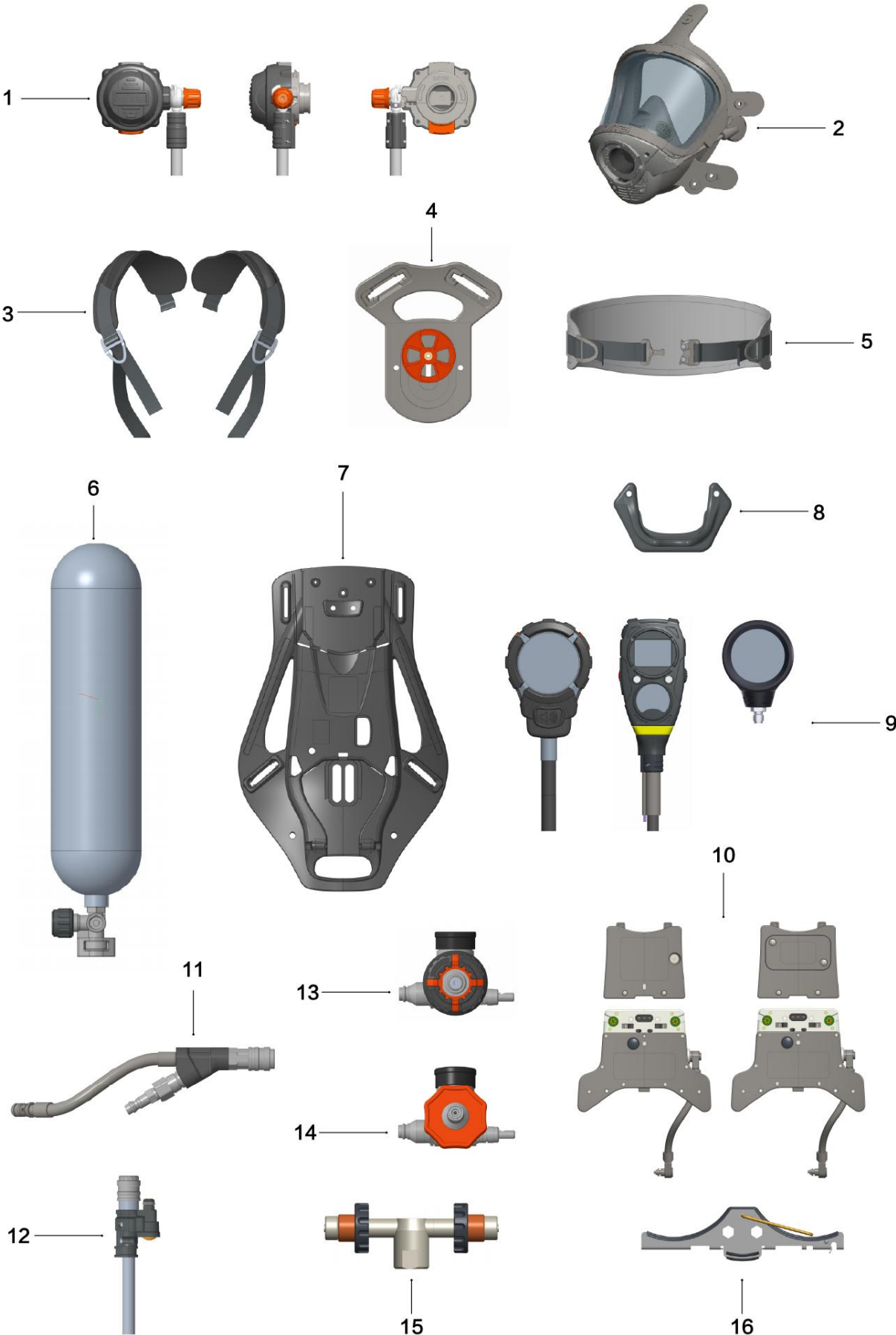

Overview of the device (Diagrammatic sketch)

- | | |
|--|--|
| 1. air supply valve assembly | 2. Full cover assembly (The S / M / L size mask is optional) |
| 3. Shoulder strap | 4. Backplate adjustment accessories |
| 5. The waist strap | 6. Cylinder Assembly-6.8L / 8L / 9L (optional) |
| 7. Backplate | 8. Backplate base (optional) |
| 9. Pressure gauge (electronic pressure gauge / mechanical pressure gauge optional) | 10. Backplate main control module (dry battery / lithium battery optional) |
| 11. Medium pressure air supply interface+He saved the interface | 12. Medium pressure supply trachea |
| 13. Threaded pressure reducer (optional) | 14. Fast interface-type pressure reducer (optional) |
| 15. Double air cylinder-connecting rod (optional) | 16. Double air cylinder-connecting rod (optional) |

2.1 Backplate assembly

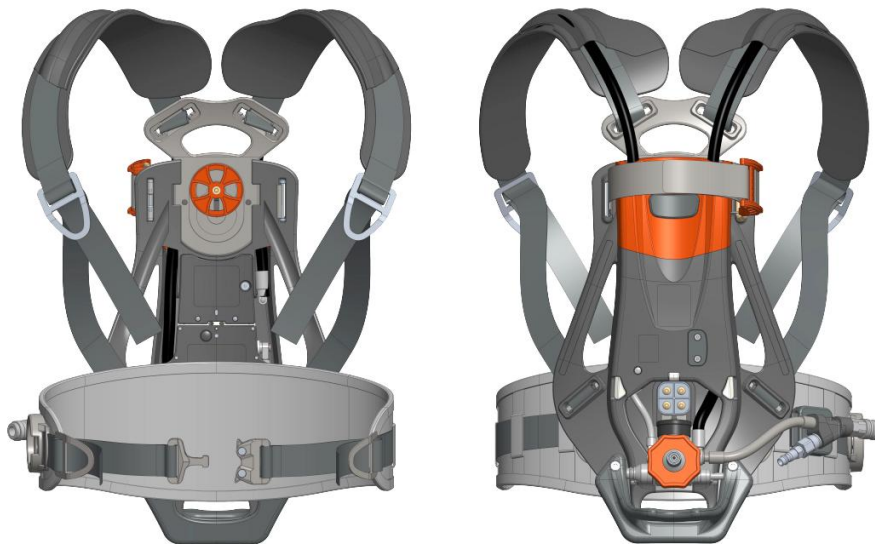

The backplane is ergonomically designed, especially for the Asian size; adjustable height for users of different height. While maintaining stability, you can make the back burden feeling more comfortable.

The structure of the backplane is designed with the up-and-down handles to facilitate the handling of the equipment. The widened belt and the waist support that can rotate up and down ,can make the waist better to support the weight of the supporting equipment and protect the waist,which makes users'

the back more comfortable. The shoulder strap, belt and cylinder belt are made of flame retardant aramid fiber with high strength and high heat resistance. The cylinder belt itself has adhesive hair and cylinder belt lock, which can quickly lock the cylinder.

2.1.1 Pressure reducer assembly

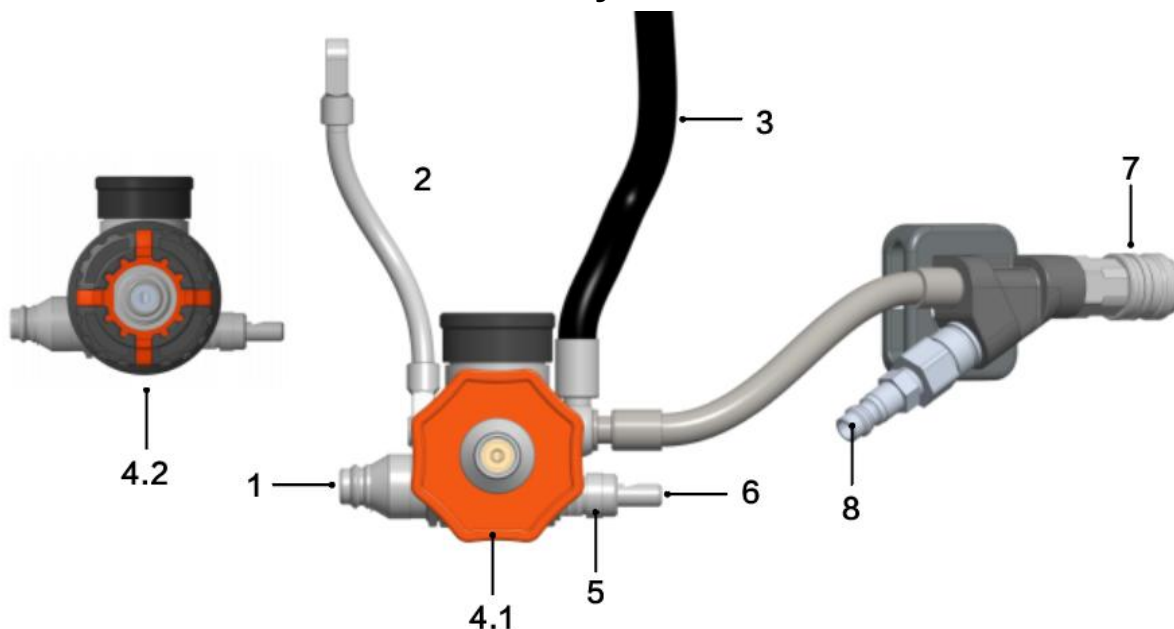

- | | | |
|--|---|-------------------------------------|
| 1. Quick inflating interface | 2. High-pressure tube | 3. Medium pressure tube |
| 4.1 Pressure interface of quick interface (optional) | 5. Safety valve | 6. Pressure pneumatic alarm whistle |
| 4.2 Thread interface of reducing reducer (optional) | | |
| 7. Other rescue interface | 8. Medium pressure air supply interface | |

The pressure reducer assembly is to decompress the high pressure air in the cylinder to the medium pressure air, and send it to the air supply valve to the air pressure of the user. The pressure relief device is equipped with a relief valve. If the medium pressure exceeds the safety range, the built-in safety valve will open the pressure relief.

The pressure reducer is installed on the lower part of the backplane to provide a stable medium pressure output regardless of the remaining air pressure and breathing rate in the cylinder.

The pressure pneumatic alarm whistle is integrated on the pressure reducer. When the pressure in the cylinder drops to 55Bar ± 5Bar, the pressure

pneumatic alarm whistle triggers the continuous alarm sound, and the peak sound intensity is not less than 90dB.

The alarm whistle continues to alarm from the beginning until the cylinder pressure drops to 10Bar.

The average air consumption of the alarm is 5 L/min from the alarm start to 10Bar.

The pressure reducer assembly with other rescue interface, Medium pressure air supply interface, Quick inflating interface

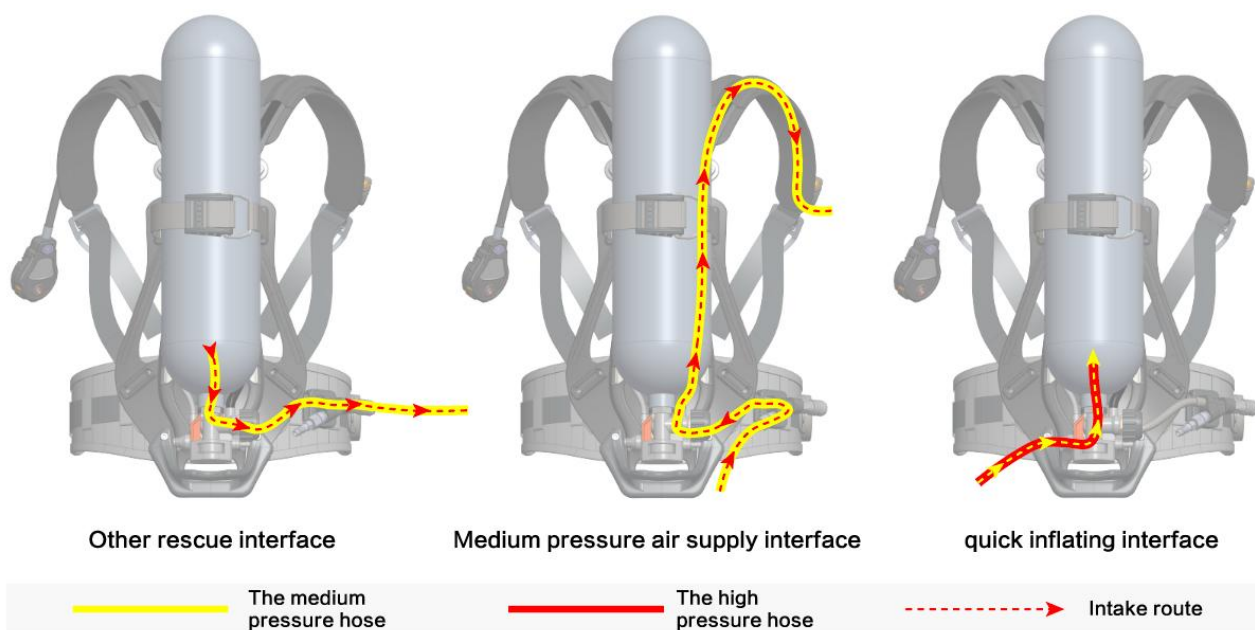

Other rescue interface: The air in SCBA can be shared with the rescued personnel during the execution of the mission, and a air supply valve can be connected for other rescue operations, so that the rescued personnel will not be suffocated by breathing due to no air in the condition of hypoxia, which effectively guarantees the life safety of the personnel.

Medium pressure air supply interface: The compressed air trolley can be connected, and The air in compressed air trolley can be used when performing tasks.

Quick inflating interface: The cylinder can be inflated in special circumstances, and the SCBA can be used normally when the air pressure is higher than 60Bar during the inflation process. Quick inflating interface can only be used for SCBA cylinders. The SCBA itself cannot be used to inflate other equipment. Quick inflating interface can reduce the cylinder replacement

frequency, shorten the emergency response time, and improve the efficiency of task execution.



Warning!

The safety pressure range of the medium pressure air source required for the medium pressure air supply interface is 80Bar-11Bar,if the air pressure beyond the safety pressure range, MTS company will not bear the consequences caused by the violation of the above warning.

The connection plug used in the quick inflating interface shall be the original quick inflating connector provided by MTS, and need the regular overhaul and maintenance. Once any air leakage or damage is found, an authorized after-sales service / maintenance personnel should be notified for maintenance, and if user was fail to follow this warning ,that may result in serious personal injury or death.

When the air pressure is higher than 270 Bar in tube which connected with The connection plug, The connection plug can connect with the quick inflating interface of SCBA. If the air pressure in tube is too low, it will cause the loss of high pressure air of SCBA itself, and not following this warning may lead to serious personal injury or death.

No unauthorized after-sales service / maintenance personnel are allowed to repair and disassemble any parts. The Company is not liable for the consequences of violating the above warning.

2.1.2 Compressed air bottle

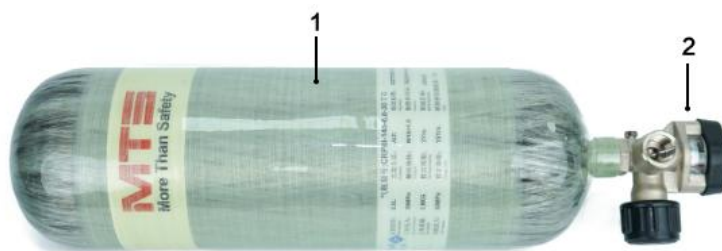

- 1、 Carbon fiber composite air cylinder 2、 Bottle valve (with pressure indication)

Compressed air bottles are used to store high-pressure compressed air, which will reduce them as inhalable air and provide them to the user. Various sizes of air cylinders can be used. Compressed air bottle was composed of a carbon fiber composite cylinder and a bottle valve (including a flow limit valve),

the cylinder valve can provide the user to transfer the pressure to the rest of the equipment. The air cylinder valve is located on the right side of the wearer. The cylinder valve has a hand wheel for switching the valves and a threaded high-pressure connector (G 5 / 8) for XF-124-2013.

The composite air cylinder is made up of high strength aluminum alloy liner, carbon fiber and glass fiber, which has the characteristics of high strength, light weight, corrosion resistance, good safety and long service life.

Bottle valve with pressure indication Regardless whether the bottle valve is open, the pressure gauge always shows the pressure of the air in the cylinder, which is convenient for the user to check the pressure of the remaining air in the bottle.

The design of bottle valve has the function of preventing accidental collision and closing, which ensures that the cylinder air supply is not interrupted due to the accident, so as to avoid the harm to the users and increase the safety of SCBA.

2.1.3 air cylinder quick-connect interface (optional)

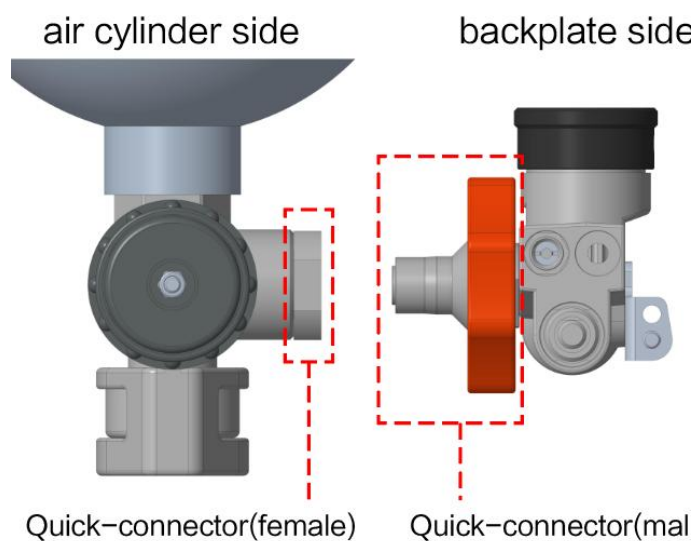

When using the quick-connect interface, tighten the cylinder quick connection base to the cylinder valve. quick-connector(male) is vertically connected with the quick-connector(female), and the "ka da" sound indicates that the installation is completed. The cylinders can be replaced quickly when using quick-connect interface .

Warning!

The quick-connect interface requires the legitimate quick-connect interface provided for MTS, and it needs regular overhaul and maintenance. Once any air leakage or damage is found, the authorized after-sales service / maintenance personnel are notified to repair maintenance. and if user was fail to follow this warning, that may lead to serious personal injury or death.

No unauthorized after-sales service / maintenance personnel are allowed to repair and disassemble any parts. The Company is not liable for the consequences of violating the above warning.

2.1.4 Air supply valve assembly

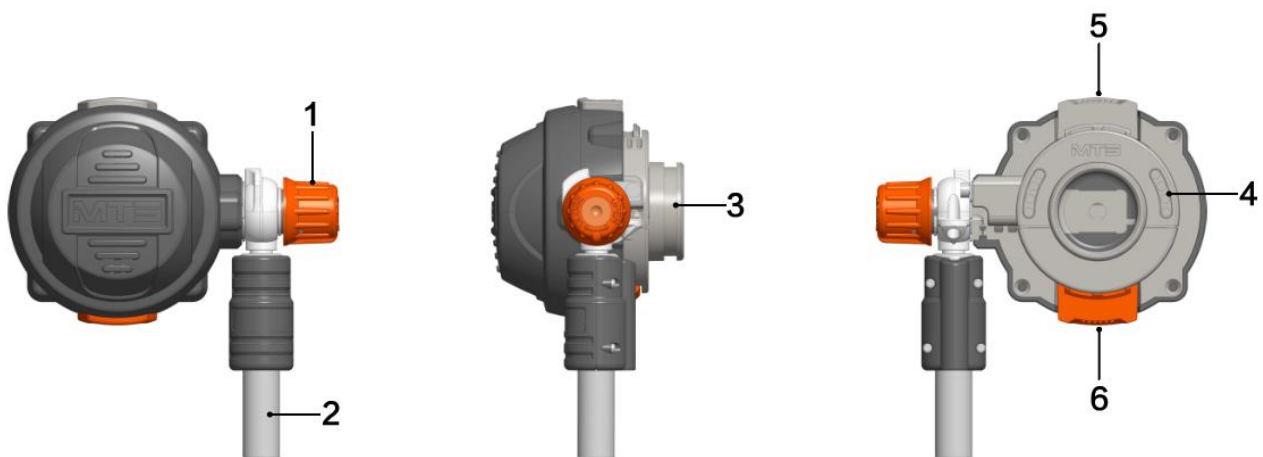

- | | | |
|--|-------------------------|---|
| 1. Emergency relief valve | 2. Medium pressure tube | 3. Full-face mask interface |
| 4. HUD and headset power supply contacts | 5. Release button (top) | 6. Release button (top) / Release button (bottom) (throttle switch) |

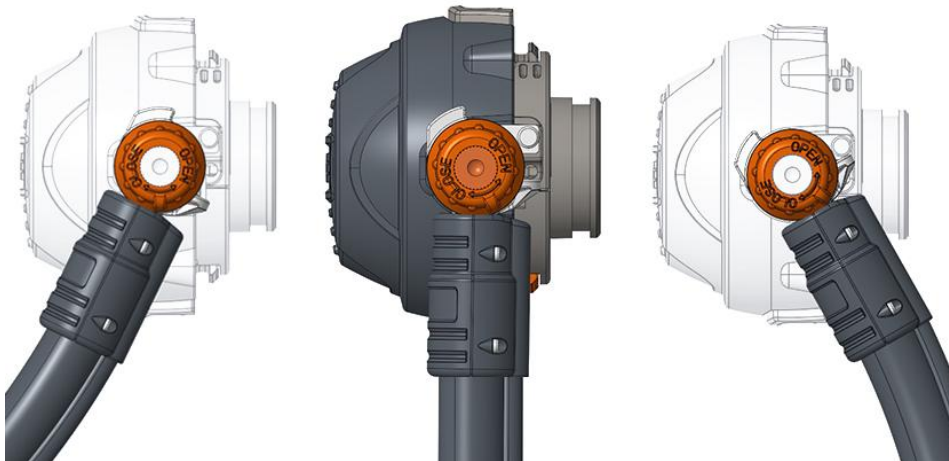

The connection between the air supply valve and the MV hose is equipped with rotary accessories that support unlimited and smooth clockwise and counterclockwise rotation.

The air supply valve is a device that reduces the medium pressure air output by the pressure reducer through the secondary pressure that the human body can breathe for the user to breathe. It can quick connect with the mask through easy lock fast interface.

The air supply valve is directly installed on the mask, and connected to the medium pressure tube of the pressure reducer through the medium pressure tube and quick-connect interface. When user disassembled the air supply valve and full-face mask, just press the upper and lower button button at the same time.

The release button at the lower part of the air supply valve is also the throttle switch. When the mask is removed from the face, hold the throttle switch with the thumb (the unloading button) to close the air supply valve and stop the air supply. When wearing the mask to inhale again, the air supply valve will automatically open to supply air.

The orange knob on the air supply valve is an emergency relief valve, which has the following three functions:

① When the air supply valve fails accidentally, turn the half circle clockwise according to the direction indicated on the emergency relief valve to provide constant air flow and allow the air in the compressed air bottle to flow directly into the mask;

- ② The outflow air can be used to directly wash the dust and dirt inside the mask and air supply valve to avoid inhalation in the body;
- ③ Release the residual air in the pipeline by opening the emergency relief valve after closing the cylinder valve.

Warning!

Do not use the SCBA before the air supply valve is properly connected. Wrong or improper installation of the air supply valve will cause air leakage or detachment from the full-face mask. Failure to follow these warnings may result in serious personal injury or death.

2.1.5 Electron device

2.1.5.1 SCBA electronic alarm device

The SCBA electronic alarm device is mainly composed of backplate module (backplate main control module + backplate battery module) and electronic pressure gauge.

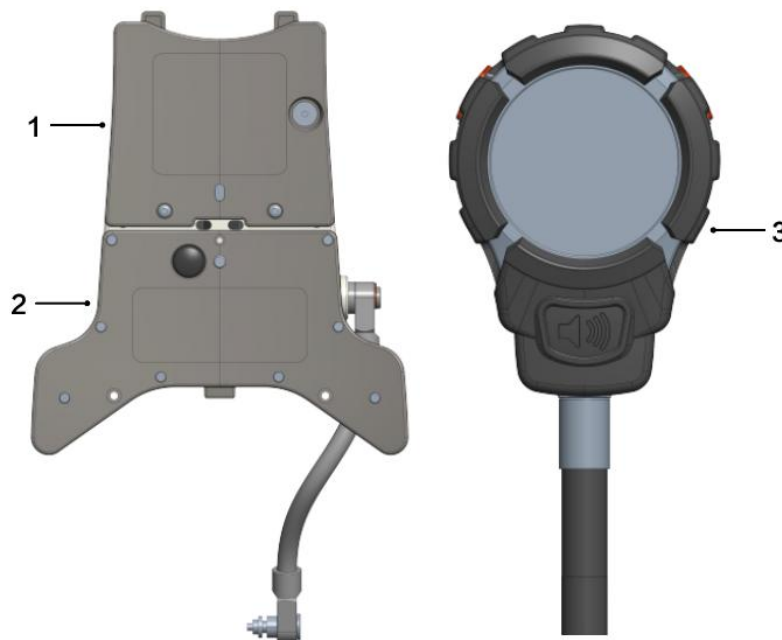

1.Backplate battery module 2.Backplate master control module
3.Electronic pressure gauge (optional)

2.1.5.2 Backplate module

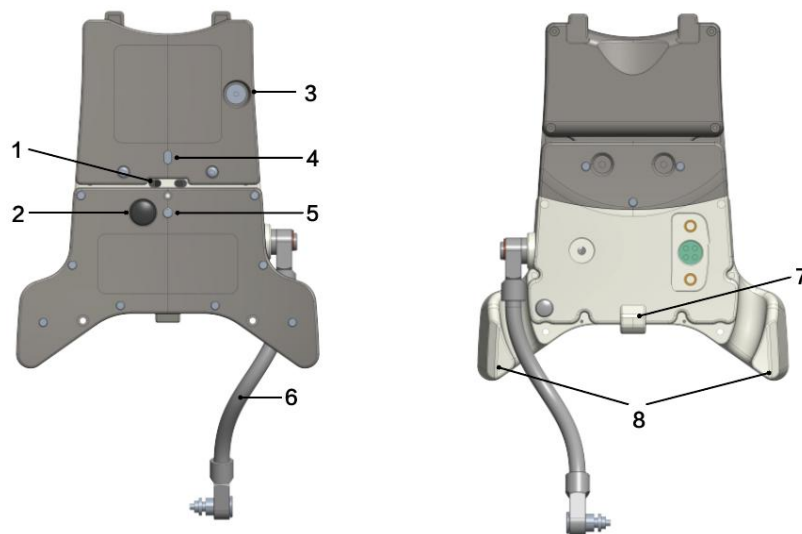

1. Battery module removal hole 2. functional switch 3. Charging contact
 4. charge lamp 5. Wireless connection indicator light 6. High-pressure tube
 7. Replace the air cylinder lighting lamp 8. Azimuth light / partner light

The backplate module includes the backplate main control module and the backplate battery module, which integrates various functions such as air pressure detection, temperature monitoring, azimuth light, and has the function to power all the electronic devices of the SCBA.

Azimuth light / partner light

The backplate module mainly realizes the air cylinder pressure detection, and transforms it into electrical signals, which are transmitted to the HUD display module and the electronic pressure gauge through the cable. It has an azimuth / partner light to identify each other in the dark or other blurred environment, and allows the companion to see and remind them whether they are in low pressure.

Replace the air cylinder lighting lamp

When the cylinder pressure drops below 14Bar, the lamp is automatically turned on, which can automatically light the pressure reducer position for about 40 seconds to facilitate the replacement of the cylinder.

Internet of System (optional)

It supports the SCBA monitoring system of the Internet of System. The equipment can wirelessly transmit the detected SCBA's cylinder pressure,

remaining time, temperature, battery power, alarm status, communication status and other data to the rear monitoring center, and supports the rear field to send individual retreat / team retreat / all retreat. See the operation manual of the empty call rear field monitoring system of the Internet of System for details.

Install the battery module

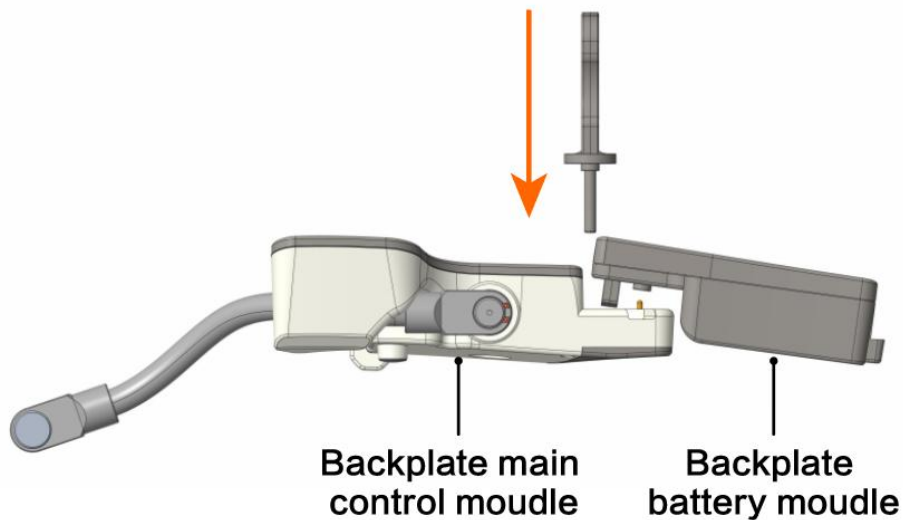

As shown in the figure above, insert one end of the backplate battery module into the backplate groove and insert the other end into the backplate main control module buckle and buckle.

Disassemble the battery module

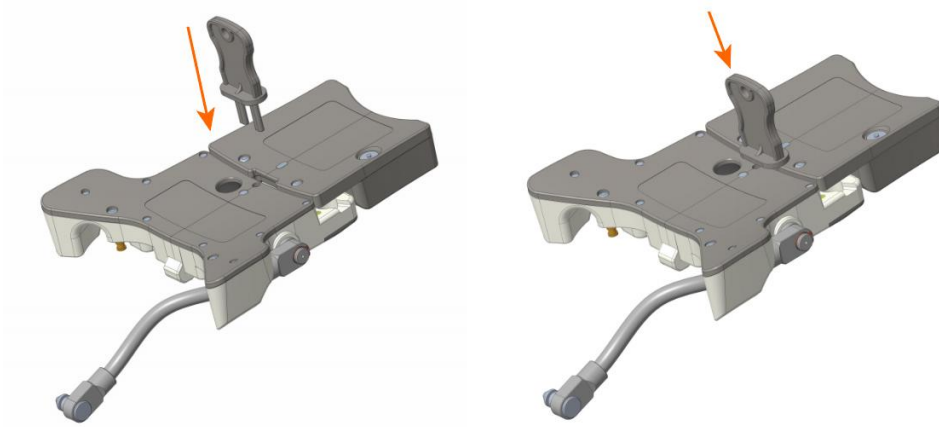

As shown in the figure above, insert the battery module key into the backplate main control module card slot, and the battery module will pop up and remove the battery.

Dry battery replacement (optional)

As shown in the right figure, assemble 3123A dry cells according to the positive and negative poles. Put it in the battery compartment.



Lithium battery module charging (optional)

Inject the end with the USB charging cable magnetic suction connector into the battery as shown on the right. Connect the charger into the 110 to 220 V power socket. The charging indicator is red and green when charged.

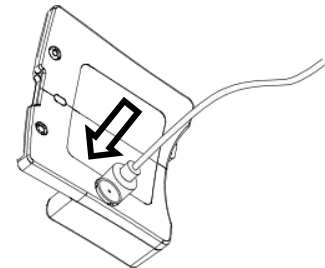

Warning!

- 1) Please use the original charger, and use the non-original charger, which may cause damage to the equipment.
- 2) Charge according to the used voltage of the charger, otherwise it will cause damage to the equipment.
- 3) The battery does not over discharge, it is best not to wait until the battery is completely out of power to charge, which may cause permanent damage to the battery.
- 4) Control the charging time, overcharging will cause battery life shortened.
- 5) If the equipment does not use the battery for a long time, please pay attention to maintenance, pay attention to the ambient temperature and humidity, do not put it in a high temperature and humidity place, keep ventilation, the battery must be kept charged, and charge the battery regularly.
- 6) The battery should be kept in a cool, dry place to avoid direct sunlight.
- 7) Do not connect the exposed poles of the battery, otherwise it will damage the battery.
- 8) Do not heat the battery or throw the battery in the water or in the fire, putting the battery into the water will make the battery ineffective, putting the battery into the fire will cause the battery to break or explode.
- 9) Do not disassemble the battery by yourself, or try to penetrate the battery with a sharp weapon, and it can explode.

- 10) Due to the physical characteristics of the battery, the battery itself is a kind of consumable, will be affected by the use of the battery, the user's habits, the temperature of the use of the environment and other factors and gradually reduce the use time.
 - 11) If the battery appears in high temperature or bulge and other phenomena in the process of charging or use, it should be stopped immediately and scrapped.
-

2.1.6 Backplate adjustment component

Backplate adjustment options

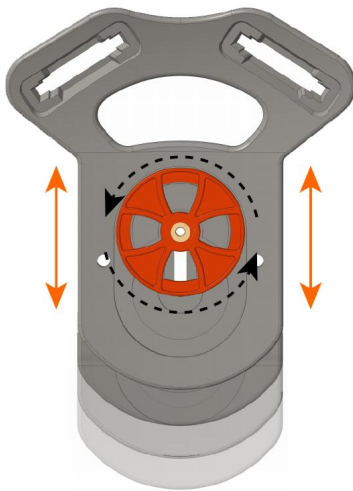

Multi-stage adjustment

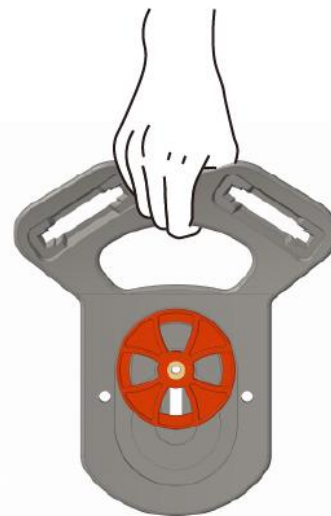

Safety towing and rescue function

The height of the backplate can be adjusted according to the height, with multi-gear adjustment function. Release the tightening knob counterclockwise, rotate and tighten the tightening knob clockwise, and adjust the length of the backplate according to the height.

It has safety towing function to ensure that rescuers can obtain stable and safe towing support in emergency.



Waist belt

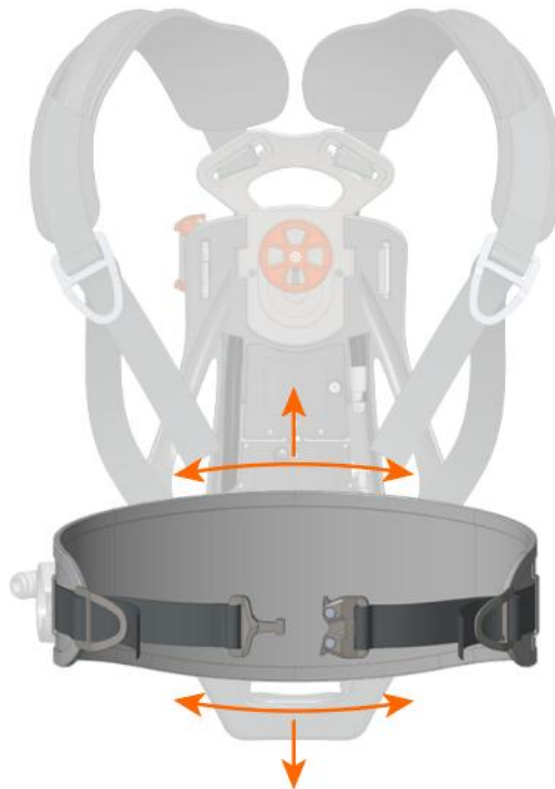

The waist belt has the function of buffering, up and down, left and right rotation adjustment. Move with the user's waist and stay in the center of the user's back.

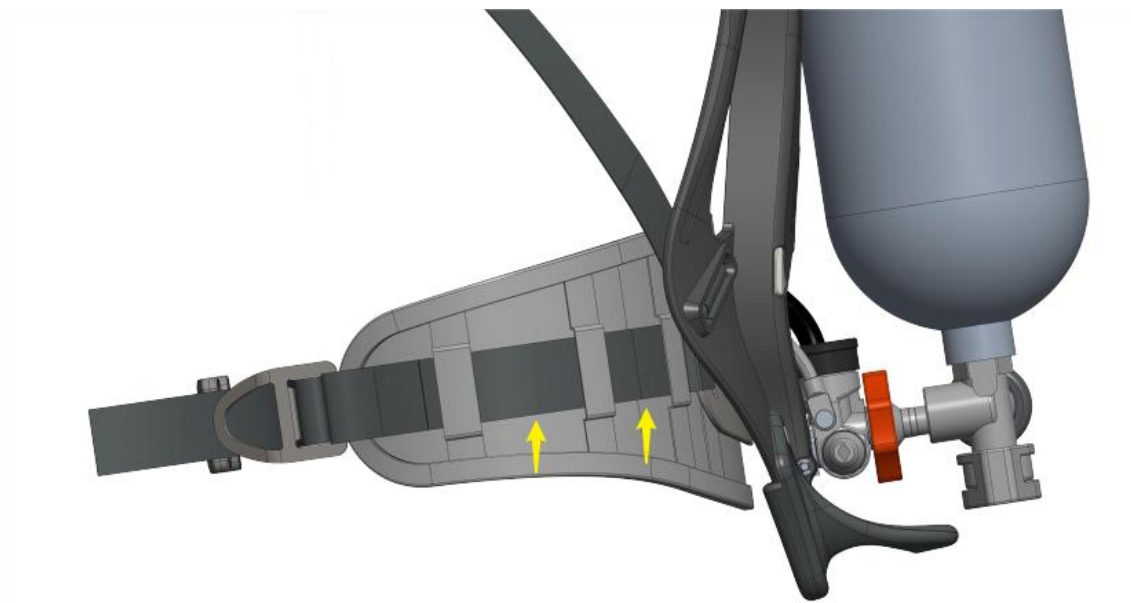

The waist belt reserved kit installation position, designed to provide convenient and stable installation, to meet the needs of users in various occasions.

Cylinder adjustment options



The cylinder belt containing metal and plastic buckle can be adjusted to different lengths, fixing the cylinder, so that the cylinder is more firmly fixed on the backplane.

The cylinder band length is adjustable.

Air cylinder with buckle assembly :

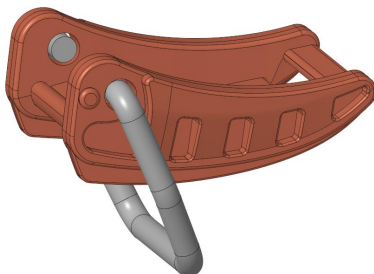

Place the cylinder buckle wire to the left, the plastic piece concave round face up

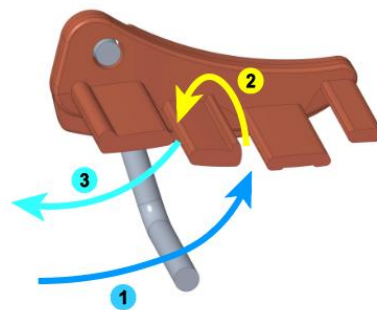

Pass the air cylinder belt into the plastic parts in turn according to the picture shown

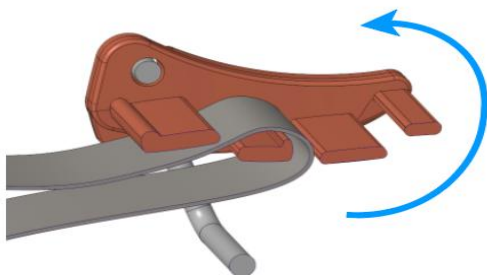

Turn the plastic parts counterclockwise

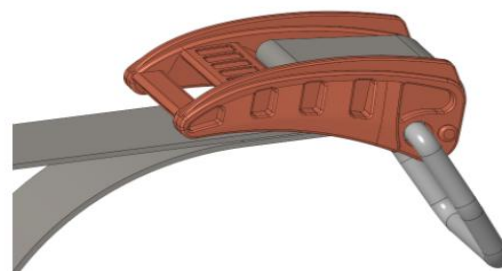

After flipping the effect

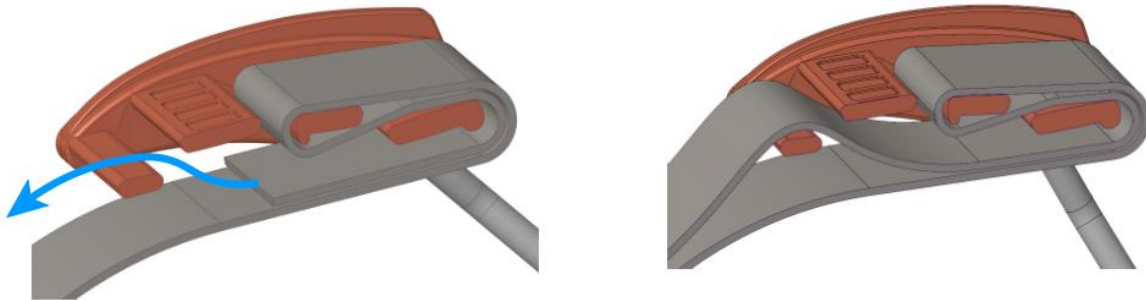

Then put the cylinder belt into the plastic parts according to the picture



Warning!

The last one step is to prevent the use of the process, due to the impact, misoperation of the plastic buckle open, resulting in the fall of the cylinder, will cause casualties.

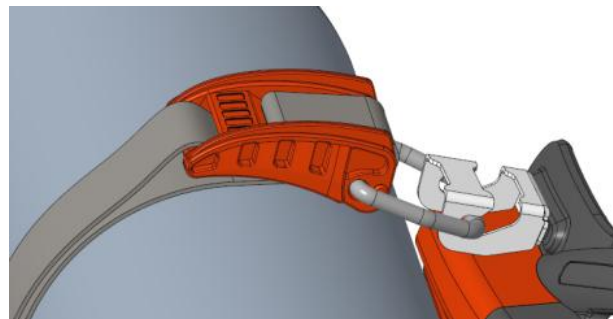

Complete effect

2.1.7 Accessories (optional)

The following accessories can be selected:

- Escape hood
- ASV(Automatic Switch Valve)
- Lap belt
- Full-face glasses holder
- Double cylinder adapter
- Rubber headwheel

Refer to the relevant operator manual for more information.

2.2 Full-face mask



- | | | | |
|-------------------------------|------------------------------|------------------|--------------|
| 1. Air supply valve interface | 2. Face screen | 3. Apical string | 4. Bandeau |
| 5. Communication headphones | 6. Hang with buckle | 7. Neck strap | 8. MIC |
| 9. Face window sealing ring | 10. The mouth and nose cover | 11. HUD show | 12. HUD show |

The full-face mask meets the requirements of EN 136-1998 Class 3 standard, which is used to cover the face, isolate toxic and harmful aires inhaled into the human body, and protect the respiratory system. It has the advantages of large vision and anti-fog.



Full-face mask are important protective equipment and must be adapted to the user's face size to ensure tight, comfortable and effective fit. Therefore, three

SML sizes are available, small (S), medium (M), and large (L default), to suit different needs.

The full-face screen is made of a high-strength polycarbonate material. The outer surface is coated with wear resistance and impact resistance; the inner surface is coated with anti-fog layer with good light transmittance and no distortion.

The face window sealing ring is made of special rubber material, which is soft, reliably sealed and comfortable to wear, and will not cause skin allergy.

The mouth and nose cover is made of elastic material to fit different wearers and minimize the fog effect of the mask.

The full-face mask has built-in HUD pressure head-up display device, using wired connection, safe and reliable, automatically open and close, and has low pressure vibration reminder (optional), to ensure all-round safety.

Full -face mask integrated communication headset (with optional function), can flexibly adjust the position of the headset, can connect the loudspeaker communication device and walkie-talkie, realize close loudspeaker communication and long distance intercom communication.

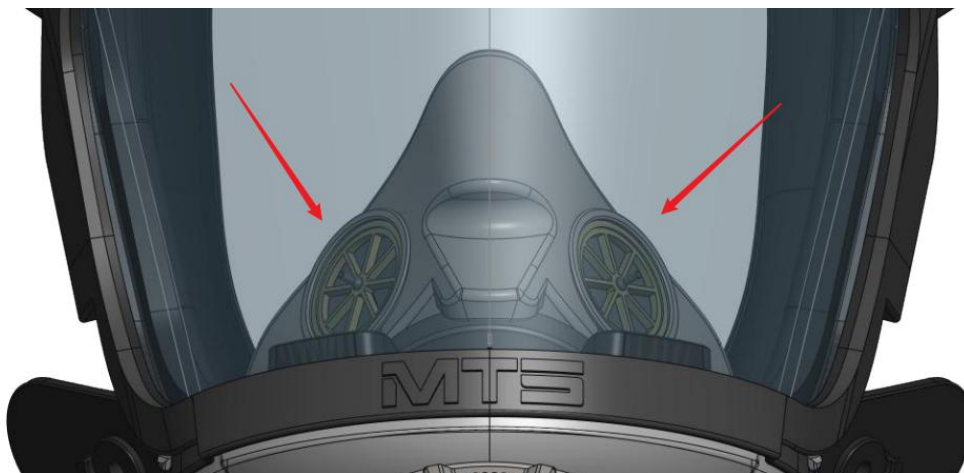

Check the suction valve sheet:

Check the suction piece for bending or missing carefully. The suction valve piece is a key component in the respirator, and its integrity and flatness are crucial to the normal operation of the respirator.

If the suction valve is bent or missing, please stop use immediately and contact professional maintenance personnel or manufacturer for replacement.



Warning

The MTS full-face mask must not be used in connection with other products or with the air supply system. Only MTS-supplied components are permitted for installation and servicing. Improper use of SCBA may result in personal injury or death.

full-face mask installation: Before using this mask, be sure to carefully check the installation.

Make sure that the components are properly installed, the retaining straps are properly adjusted, and the face is firmly seated. Improper installation, for example, if the face mask is not tightly attached to the face, may lead to the failure of protection, exposing you to dangerous environment and seriously endangering your life and health.

Full-face mask sealed: If your face hair or glasses feet pass between the mask seal rubber and the face, the mask will not be able to seal properly. This may lead to the intrusion of harmful aires or substances during use, thus not providing effective protection.

Oxygen and High Oxygen Environment: Potential hazards exist in oxygen and air with high oxygen concentrations. Excessive oxygen concentrations may increase the risk of fire or explosion. Especially in the presence of inflammable materials, high oxygen environment can easily lead to catastrophic combustion and explosion accidents.

Air quality: Pay close attention to the air quality of the environment. Extremely poor air quality can damage the filter components of the mask, causing it to deteriorate significantly.

Explosive environment: Do not use this equipment in an explosive atmosphere. Any possible spark, static electricity or overheating can cause a violent explosion, causing extremely serious casualties and property damage.

other protection: If other protective measures are required in addition to respiratory protection, the protective equipment shall comply with relevant European Standard requirements.

2.2.1 The HUD module

The HUD module is integrated in the mask, receiving the input signal of the main control module of the backplane, and displays the cylinder pressure status and other state information of the system in real time. The built-in HUD in the mask has vibration reminder function (optional) and luminous reminder function to remind users to pay attention to safety.

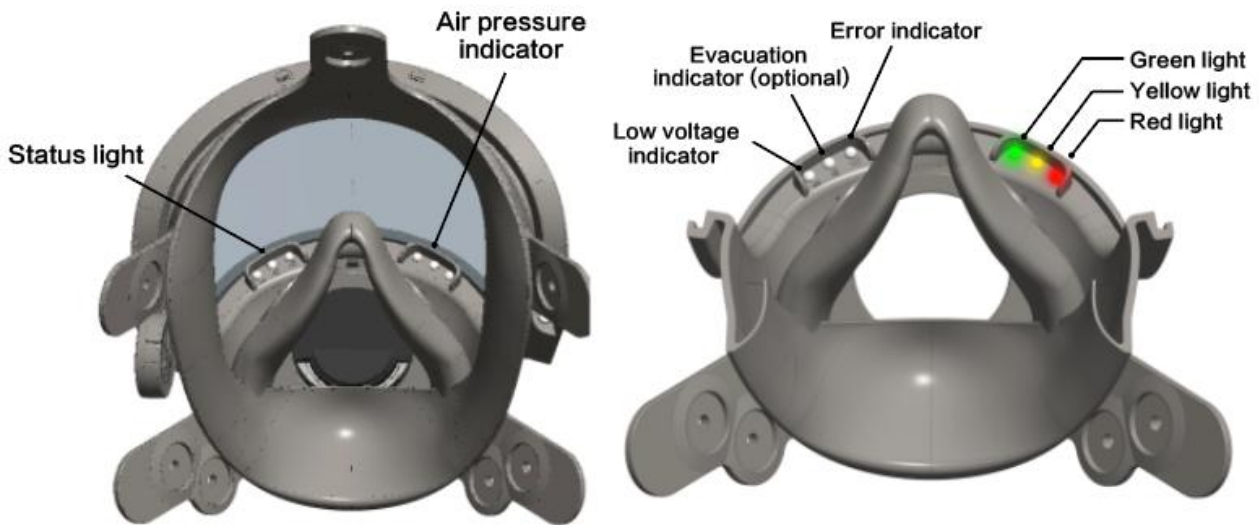

Cylinder pressure	Indicator light	Vibration (optional)	Colour of indicator light
270~300Bar	Three green light	None	● ● ●
180~270Bar	Two green light	None	● ● ○
100~180Bar	One green light	Once vibration reminder	● ○ ○
60~100Bar	Yellow light is always on	Thrice vibration reminder	○ ● ○
Below 55Bar ± 5Bar	Red light is flashing	Intermittent vibration	○ ○ ●

Warning!

When the pressure is lower than 55Bar ± 5Bar low pressure alarm starts, it must immediately evacuate to the place that does not need respiratory protection, otherwise casualties may occur.

2.2.2 Mask communication system (optional)

The mask integrates MIC and headphone module, extends to the left shoulder strap audio fast connector through the cable, with optional loudspeaker communication device to realize the near amplification function and connect the loudspeaker communication device.

2.3 Electronic pressure gauge (optional)

Refer to the relevant operator manual for more information.

2.4 Mechanical pressure gauge (optional)

Mechanical pressure gauge can easily check the residual pressure in the bottle, and has the function of luminous display, easy to observe under the condition of insufficient light. The accuracy of the mechanical pressure gauge is grade 1.6.

3 Appearance test

See Section 8 for the maintenance interval of relevant equipment, and conduct visual inspection after receipt.



Warning!

- If there is a risk of exposure to harmful pollutants, do not check the SCBA before decontamination, cleaning and disinfection. Follow the applicable decontamination procedures, first clean and disinfect the SCBA, and then check it.
- If the SCBA is damaged, deteriorated or fails any of the requirements listed in the Visual Inspection section, stop using the equipment and send it to the MTS Training certified maintenance technician. Only SCBA that are fully maintained and tested can be used. If any faults or defects are found before use, it shall not be used under any circumstances.
- Do not replace, alter, add, or omit any components. Only you can use the MTS to specify the same replacement components in the configuration. Failure to follow these warnings may result in serious personal injury or death.



Warning!

If the SCBA has any of the requirements listed in the Visual Inspection section, stop using the device. Verify that the MTS training-certified maintenance technician has corrected all issues before reusing the equipment.

Failure to follow this warning may result in serious personal injury or death.

**Warning!**

This product protects life and health and is directly related to life safety. No one may casually disassemble this product into parts, use it with other brands or models and air supply system, or modify, add or omit any components. Only you can use the MTS to specify the same replacement components in the configuration. Otherwise, serious personal injury or death may result. The company shall not bear any legal responsibility for the consequences, and shall not assume any economic responsibility.

No unauthorized after-sales service / maintenance personnel are allowed to repair and remove the bottle valve and any other parts. The Company is not liable for the consequences of violating the above warning.

All components

- 1) Check all components for deterioration, dirt, cracks, debris, tears, holes, viscosity, heat traces, chemical related damage or other obvious signs of damage.
- 2) Check all shoulder straps (strap, pull, belt, full cover strap) for tears, cuts, wear, missing buttons or strap.
- 3) Perform all the component designation checks listed below.

3.1 Air bottle

- Confirm the use of MTS RHZK series positive pressure fire air respirator approved cylinders, and fully comply with the relevant national regulatory requirements.
- Before using the compressed air bottle, you must carefully read and understand the warnings and instructions on the cylinder body, and check the test date located on the sticker on the cylinder label.
- The service life of the carbon fiber composite air cylinder is 15 years, and it is strictly prohibited to use it after exceeding the service life.
- Carbon fiber composite cylinders shall be inspected regularly with a period of no less than 3 years.
- If serious corrosion, damage or safety doubt is found during the use, the cylinder shall be checked in advance.
- If the composite cylinders was in stock or withdrawn for longer than one inspection cycle ,it shall be inspected prior to commissioning.
- The inspection institutions for periodic inspection of composite air cylinders shall meet the requirements of GB12135 and be approved by the national special equipment safety supervision and administration department.

- **Inspection items are as follows (but not limited to):**
- 1) Appearance inspection: marking inspection, surface wear, scratches, impact damage, stratification, thermal damage, structural damage, chemical corrosion damage, etc;
- 2) Internal check;
- 3) Bottle mouth examination;
- 4) Water pressure test;
- 5) Volume residual deformation rate: the volume residual deformation rate should be determined simultaneously during the hydrostatic test;
- 6) The interior dry;
- 7) Inspection and installation of the bottle valve;
- 8) air leakage test;
- 9) Certification label;



Warning!

- air cylinders undergoing collision, fire or other damage shall be stopped during use.
- Found a fiber fracture, damage, or obvious scratches, should not be filled. It is forbidden to fill air cylinders, to manually heat cylinders or to expose air cylinders in the sun.
- The rated working pressure of the cylinder is 300Bar, and it is strictly prohibited to exceed its rated working pressure.
- The equipment for filling the air cylinders shall comply with the regulations of the GB17264.
- air filling personnel must undergo special training to obtain the operation certificate of special filling air equipment operators.
- air filling shall comply with the provisions of GB14194、 EN 12021.
- Filling air should be filled directly by atmospheric compression, and nitrogen and oxygen bodies are not allowed to mix, and oxygen is not allowed to be filled, so as to avoid the explosion of oil in the cylinder after hyperbaric oxygen, and other aires and liquids cannot be filled into the cylinder.
- The air in the cylinder shall not be exhausted, and the remaining pressure above 5Bar shall be left.
- No unauthorized after-sales service / maintenance personnel are allowed to repair and remove the bottle valve and any other parts.
- The Company is not liable for the consequences of violating the above warning.

4 Functional test



Warning!

If the SCBA fails to perform all functional tests properly, deactivate the device. Verify that the MTS training-certified maintenance technician has corrected all issues before reusing the equipment. Failure to follow this warning may result in serious personal injury or death.

If the SCBA has successfully passed the visual inspection, the functional testing can be performed.

If any part of the SCBA fails the functional test, do not use the equipment and send it to a certified maintenance technician.

Attention: Functional checks must be performed with fully filled cylinders. Before starting the test, check the pressure gauge on the cylinder valve to confirm that the cylinder is full.

4.1 Check the sealing ability of the pressure reducer

- (1) Connect the compressed cylinder (see Section 7.3 "Rereplace the cylinder");
- (2) Open the cylinder valve and check the operating pressure on the pressure gauge;

For a cylinder of 300Bar, the pressure value must be at least 270Bar.

- (3) Close the cylinder valve;

After 60 seconds, the pressure drop in the pressure gauge shall not exceed 10Bar.

- (4) Confirm warning device:

- a) Connect the air supply valve;
- b) Open the cylinder valve to pressure the equipment;
- c) Close the cylinder valve;
- d) Observe the pressure gauge;

- e) Start the air supply valve air supply mode to release all the air pressure;

For 300Bar cylinders, the air supply valve shall force the air supply, slowly release the pressure to 55 ± 5 Bar, and check whether the alarm is normal.

**Warning!**

- 1) Test pressure must be above 270Bar.
- 2) Once air leakage is found, authorized aftermarket service / maintenance personnel are notified to perform repairs, and failure to follow this warning may result in serious personal injury or death.
- 3) No unauthorized after-sales service / maintenance personnel are allowed to repair and disassemble any parts. The Company is not liable for the consequences of violating the above warning.

4.2 Pressure check

Slowly rotate the handwheel of the bottle valve in the counterclockwise direction, open the cylinder valve, and observe the cylinder pressure displayed by the electronic pressure gauge, which should be not lower than 270Bar, if lower than this pressure value. Please inflate before use.

**Warning!**

If the air pressure is too low, it will affect the duration of SCBA use.

4.3 Air cylinder harness tightening check

Pull the cylinder belt up and down, which should not move up and down, indicating that the cylinder belt has been fastened. If not, readjust the cylinder band length to tighten it.

The cylinder belt has an anti-shedding mechanism, and the buckle should be in place according to the drawing to prevent the release of external forces in the cylinder during use.

**Warning!**

If the cylinder belt is not tightened and used in accordance with the regulations, the cylinder will shift or even fall off, which may lead to serious personal injury or death. They shall not bear any legal responsibility or bear any economic responsibility for their consequences.

4.4 Low air pressure alarm check

Open the cylinder valve and close the cylinder valve after full pressure. Slowly rotate the orange knob of the emergency pressure relief valve counterclockwise until the air slowly flows out. Observe the electronic pressure gauge. At 55 ± 5 Bar, the electronic pressure gauge and the pneumatic alarm should start to alarm. The electronic pressure gauge sends out a low pressure sound and light alarm, and the pneumatic alarm calls is normal.

4.5 Check the full-face mask and the air supply valve function

4.5.1 Check the air tightness and the discharge valve function

Connect the supply valve to the respirator medium pressure tube. Make sure the supply valve is closed before opening the cylinder valve. Then open the cylinder valve, check for air leakage, open and close the discharge valve immediately, and confirm that the discharge valve can be opened and closed normally.

4.5.2 Mask function

Install the mask and air supply valve on a professional positive pressure SCBA tester for respiratory resistance testing. Note that the matching SCBA test should be MTS supporting products.

4.5.2.1 Static pressure determination

Will cover the air to wear on the head mold, the breathing interface is connected with the ventilator, in the air supply valve is closed in the cylinder valve completely open, start the ventilator to do several slow breathing, and then stop the breathing, such as the system air path balance, record the air supply valve opening pressure, valve opening pressure, static pressure, the air supply valve can open normally, the static pressure is not greater than 500Pa, and the static pressure is not greater than the opening pressure of the valve.

4.5.2.2 Dynamic respiratory resistance measurement

The test steps are as follows:

- 1) Wear the comprehensive cover tightly on the head mold, the breathing interface is connected to the ventilator, set the ventilator breathing frequency is 40 times / min, the breathing flow is 100 L/min, fully open the cylinder valve, and start the ventilator. Within the pressure range of 300 Bar

to 20 Bar, always keep positive pressure in the respirator cover, and the suction resistance should not be greater than 500Pa, and the expiratory resistance should not be greater than 1000Pa.

- 2) Set the ventilator breathing rate of 25 times / min, the respiratory flow of 50 L/min, within the pressure range of 20Bar~10Bar, the positive pressure should be maintained in the full cover of the respirator, and the inspiratory resistance should not be greater than 500Pa, and the expiratory resistance should not be greater than 700Pa.

**Warning!**

- 1) The full cover and air supply valve shall be the original joint products provided for MTS, and regular repair and maintenance. In case of air leakage or damage, the authorized after-sales service / maintenance personnel are required to do repairs. Failure to follow this warning may lead to serious personal injury or death.
- 2) No unauthorized after-sales service / maintenance personnel are allowed to repair and disassemble any parts. The Company is not liable for the consequences of violating the above warning.

4.6 Electronic equipment inspection

Open the cylinder valve, check whether the pressure display of the electronic pressure gauge (optional) is normal and whether other functions are normal, and check the battery power. And observe whether the HUD pressure display is normal, whether there is error information, etc. Close the bottle valve, rotate the orange knob of the emergency pressure relief valve counterclockwise, and slowly release the air in the pipeline, when the pressure drops to 55Bar \pm 5Bar, sound, light and vibration alarms shall start working.

5 Adorn

**Warning!**

Devices must be worn before entering a dangerous area.

- 1) Before entering the hazardous area, check for mechanical damage to the SCBA.

- 2) If the SCBA fails to operate properly as described in this section, the equipment must be deactivated and the MTS training certified maintenance technician must be corrected for all problems before using the equipment.
 - 3) Do not use the device when the user's beard, sideburns or glasses holder prevents the sealing of the face and mask. Incorrect face seals may allow contaminants to penetrate into the full mask, resulting in reduced or weakened respiratory protection. It could cause casualties. The full mask seal must be checked before each use.
 - 4) The mouth and nose mask must be installed in a full-face mask.
 - 5) In order to ensure that the mask and the personnel wearing glasses can properly fit, a special glasses frame must be worn, because general glasses cannot be worn under the mask.
 - 6) Do not remove the full-face mask unless in a safe, harmless and non-toxic environment.
 - 7) The user must wear suitable protective clothing and must take precautions so that the equipment is not exposed to environments that may be harmful to them.
 - 8) Failure to follow these warnings may result in serious personal injury or death.
-

5.1 Prepare

Before use, the equipment must pass all visual inspection and functional tests (see previous section).

- (1) Confirm that the cylinder is fully pressurized;
- (2) Check cylinder connection:

threaded connection :

Check that the handwheel is tightened by hand (do not use tools).

Quick connection:

Pull the quick connection interface to confirm a secure connection.

- (3) Pull the cylinder belt assembly to confirm that the cylinder belt is firmly connected;
- (4) Fully spread out the shoulder strap and belt;
- (5) Adjust the backplate height:
 - a) Release the adjustment knob and pull the handle adjustment block on the backplane to push up or down as required;
 - b) After tightening the adjustment knob, pull up or down to confirm that the belt block is fastened.

5.2 Wear SCBA

The straps component design focuses on fast wear, stable and durable, even wearing gloves can be easily adjusted fastener, easy to operate, strong impact resistance, to provide stable and reliable support for users.

The SCBA wearing mode:

Pass the right arm through the right strap and the left arm to confirm the right orientation; place the arms and lean slightly forward to place the SCBA on the back.



Lean forward, pull down the shoulder adjustment belt at the same time to the appropriate position (subject to comfort), insert the belt lock, hold the waist adjustment belt forward at the same time, and pull to the appropriate tightness according to the waist circumference.



5.3 Wear a mask

5.3.1 Full-face mask wearing method

Release the tightening belt of the head net completely, hang the neck belt of the full-face mask on the neck, hold the bottom of the mask with the left hand, and let the right hand open the head net into the head, and stick the face to the rubber face of the mask. Make the top belt in the middle of the top of the head, the head net is placed in the back of the head position, each head belt should be smooth without winding.

- At the same time, pull the left and right neck to tighten to the right tightness ;
- Also pull back the sides of the head and tighten the belt to the right tightness;
- Pull the top back to tighten it to the right tightness.



5.4 Install the air supply valve and check the breathing performance of the air pager

5.4.1 Full-face mask sealing check



Block the interface between the mask and the air supply valve with the palm of your hand, breathe deeply and hold your breath for a few seconds. If you feel the mask is tight to the face, and there is no air flow in the mask, indicating that the mask and face are well sealed, otherwise it is necessary to readjust the head band or wear the mask again.

On the premise of ensuring good air tightness, it is not necessary to pull the mask head tape too tight.

When the temperature difference between inside and outside is large, just start wearing the mask, the face screen may have a fog phenomenon. After connecting the air supply valve to breathe, the fog will be eliminated.



Warning!

SCBA should not be worn when the user's beard, sideburns or glasses holder prevent the sealing of the face and mask.



5.4.2 Open the bottle valve

Turn the emergency discharge valve knob to "CLOSE" clockwise to the end, and check whether the throttle switch is closed. Rotate the bottle valve handwheel counterclockwise for at least 2 turns.



Warning!

Listen carefully for hissing or popping sounds during device pressurization. If you hear a hissing or pop sound, discontinue the SCBA device and send it to an authorized aftermarket service / maintenance person for repair.

Warning!

Failure to follow this warning may result in serious personal injury or death.

5.4.3 Install air supply valve

Place the outlet of the supply valve on the air inlet of the mask and hear a "click" indicating that the supply valve and the mask are connected. If the air supply valve cannot be installed to the mask, check whether the sealing ring on the air supply valve is damaged and the sealing surface of the mask and the air supply valve are damaged. The specific steps of the alignment of the outlet of the air supply valve with the mask inlet are as follows:



picture 1



picture 2

Step 1: As shown in picture 1, use the right index finger and thumb to accurately pinch the release button (top) and release button (bottom) to ensure the stable removal from the air supply valve base. Be sure to keep the orange button (emergency discharge valve) unchanged, that is, maintain the left horizontal position, as shown in picture 2;



Picture 3



Picture 4

Step 2: As shown in picture 3, continue to the left level and smoothly move the air supply valve toward the mask air intake;

Step 3: As shown in picture 4, when the air supply valve approaches the mask inlet, gently move the index finger of the right hand to the orange button (emergency relief valve) to form a figure of eight with the thumb.



At this time, the outlet of the supply valve is aligned with the air intake of the mask, and appropriate pressure is applied to ensure that the supply valve is tightly connected to the mask. When the "click" is heard, it means that the air supply valve has been successfully installed on the mask and can be worn through and taken off in 60 seconds.

Precautions for air supply valve installation:

- 1) Place the protruding step of the supply valve into the air inlet gap of the mask and hear a "cada" that the supply valve and the mask are connected.

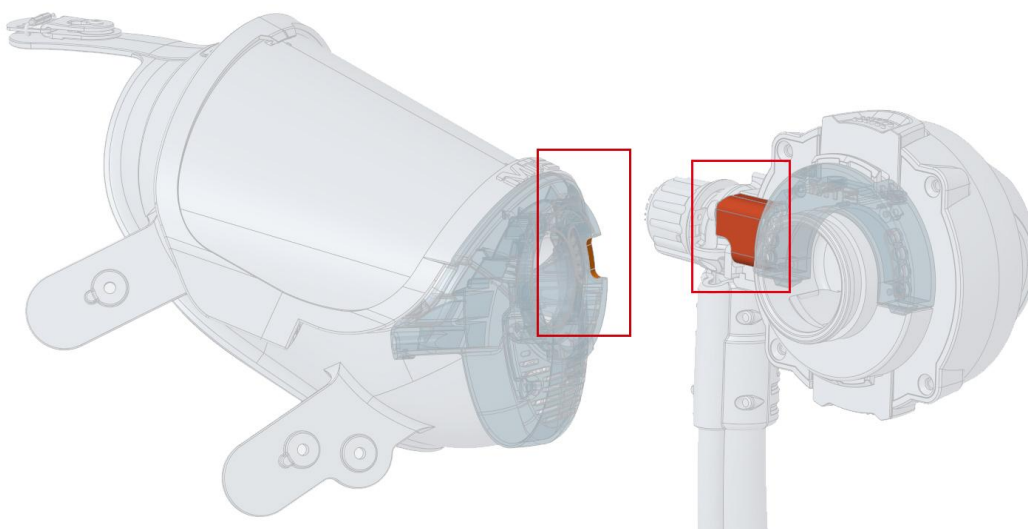

- 2) Pull the air supply valve to confirm that it is accurately connected to the full-face mask. If the air supply valve cannot be installed to the mask, check whether the sealing ring on the air supply valve is damaged and the sealing surface of the mask and the air supply valve are damaged.
- 3) After the air supply valve is installed, take a deep breath, open the air supply valve, and then inhale will automatically supply. Inhale and exhale should be comfortable, no air supply feeling, can be deep by several times to check the performance of the air supply valve. Check whether the working status of HUD and the electronic pressure gauge pressure display is normal, and use it normally if everything is normal.



Warning!

Never use SCBA before the air supply valve is accurately connected. Ensure that the air supply valve is correctly connected to the mask before use. Incorrect installation of the air supply valve will cause accidental separation from the full cover. Failure to follow these warnings may result in serious personal injury or death.



Warning!

If there is no automatic air supply during the first inhalation, please check whether the bottle valve is opened and the mask is well sealed with the face, and observe the pressure gauge to confirm whether there is pressure in the cylinder.



Warning!

The SCBA is readily available if it passes all the tests. An all-directional self-test must be conducted before entering a dangerous environment. If the SCBA fails any of the tests, these conditions must be corrected before using the device.

6 Termination of use

6.1 Remove face cover

The work shall be confirmed in a safe environment and respiratory protection can be stopped;



Remove the air supply valve: The thumb and index finger must hold the unloading button and the throttle button (the unloading button) to pull the air supply valve from the mask and ensure that there is no air out of the air supply valve. Be sure to keep the position of the orange button (emergency discharge valve) still, that is, maintain the horizontal position to the left, and smoothly move the air supply valve to the base of the air supply valve, apply appropriate pressure, and hear the "cada" sound, indicating that the air supply valve is successfully installed on the base of the air supply valve.



Close the cylinder valve: Hold the bottle valve handwheel, press inward and rotate the bottle valve handwheel clockwise to the OFF state, and close the bottle valve.



Air discharge pipeline: Rotate the emergency relief valve counterclockwise to adjust to the OPEN state and empty the residual air in the pipeline. After the residual air in the pipeline is empty, the electronic pressure gauge will automatically close after the low pressure alarm, and the HUD pressure shows the automatic closing after the electronic pressure gauge is closed.

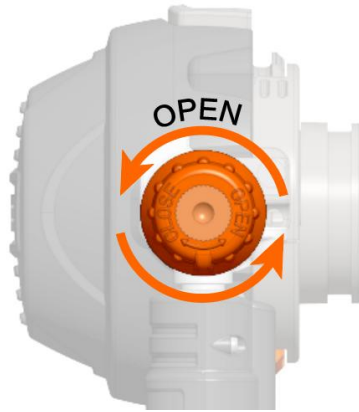

Place the air supply valve: The air supply valve returns to the air supply valve seat when not in use.

Remove the mask: Pull the stainless steel buckle on the mask head belt to loosen the head belt, grasp the front end of the mask to pull outward, take off the mask from the face, turn the head net over the screen, prevent scratches of the screen, and put it into the mask bag.



Warning!

After closing the throttle switch (lower unloading button), do not affect the normal operation of the emergency discharge valve. If the emergency relief valve is unwound, the air in the compressed air bottle will continue to be consumed heavily.

If the air leakage situation occurs:

- 1) Press and hold the throttle switch (unloading button) to close the air supply valve;
- 2) Close the emergency relief valve.

**Warning!**

If it is confirmed that the throttle switch (lower release button) and the relief valve are closed and air is still flowing out of the air supply valve, the bottle valve should be immediately shut down to prevent the consumption of remaining air in the cylinder. Stop to mark it and contact for after-sales service.

6.2 Discharge back gear



Loosen the belt: Pull the metal slip and free buckle on the left and right sides of the belt respectively, loosen the belt, push the thumb and index finger to the waist buckle orange lock switch to the right, and separate the belt buckle.

Loosen the shoulder strap: Pull the left and right metal buttons of the shoulder strap respectively, loosen the shoulder strap. Grab the shoulder strap to remove the SCBA.

**Warning!**

After using part of the air, if you want to reuse it, you must assess whether the remaining air can be enough to maintain life.

When the SCBA is not in use, the bottle valve must be closed. Otherwise, the throttle switch (lower release button) may be opened due to accidental collision or other reasons, consuming the air in the cylinder.

Do not let the SCBA fall off the body when unloading. Failure to follow this warning may result in serious personal injury or death.

**Warning!**

Be sure to replace the filled air cylinders. Complete the inspection, decontamination, cleaning, and disinfection procedures listed in the specified manual. Confirm that the whole respirator is clean and dry. Confirm that the full header and strap strap are completely released. Place the entire SCBA in a dedicated box or suitable storage location for emergency use. (Please see the storage instructions.) If users will use SCBA differently, the air supply valve and the full cover must be cleaned and disinfected with disinfectant to prevent cross-infection between users.

6.3 Replacement of cylinder

Disassembly of cylinder

- (1) Make sure that the bottle valve is closed, slowly open the emergency discharge valve, release the residual air in the pipeline until there is no airflow, confirm that all the compressed air in the system except the cylinder has been released, and then close the emergency relief valve.
- (2) Place the SCBA horizontally, with the cylinder partially facing up. Break the cylinder belt lock, tear the barbed hair buckle, and release the cylinder belt.
- (3) Disconnect the cylinder connection:
 - Threaded connection :*
 - ✓ Turn the cylinder valve assembly.
 - Quick interface connection :*
 - Release the connector clockwise and press down toward the pressure reducer when at the stop position;
 - Release the cylinder connector.
- (4) Remove the pressure reducer from the bottle valve and remove the air cylinder.

Installation of cylinder

- (1) Place the SCBA backplate horizontally, with the cylinder facing up;
- (2) Push the air-filled cylinder into the bracket;
- (3) Open the cylinder buckle on the cylinder belt and release all the belt with the longest belt (please chapter 2.1.6 for assembly);
- (4) Pass the cylinder through the cylinder belt and face the cylinder valve toward the pressure reducer to place it on the cylinder base;

(5) Cylinder connection:

Threaded connection :

If necessary, connect the cylinder valve thread to the pressure reducer, and put the respirator on the valve vertically.

Quick interface connection:

Axially align the cylinder and install it on the fast interface connector; Gently apply to hold the connector together.

**Warning!**

Never overforce the engaging connector device.

(6) Pull the remaining pull belt to tighten the cylinder belt and buckle;

(7) Check the cylinder position and please re-tighten if necessary;

**Attention!**

Using too much effort can cause damage and make the respirator unusable.

(8) Do not over tighten the cylinder belt;

(9) Place horizontally (the cylinder part is facing up), tighten the adhesive buckle, and then press the cylinder belt lock in the direction of the back frame. Hearing the "ta" sound, it means a tight button. Determine that the cylinder band does not move easily on the cylinder body, indicating that the cylinder band has been tightened;

(10) Open the cylinder valve briefly and check for air leakage and tighten again if necessary;

(11) To check that the cylinder is firm, place one hand on the back plate and grab the cylinder valve with the other hand. Try pulling the cylinders and valve down from the bracket. Confirm that the cylinder belt holds the cylinder in the bracket;

(12) Align the handwheel assembly with the cylinder valve;

Threaded connection:

✓ Check the O-ring, clean and damaged before installing the hand-wheel; if the O-ring is damaged, it must be replaced before using SCBA;

✓ Turn the hand wheel onto the thread of the cylinder. The hand wheel should be tightened by hand (no tools are used).

Quick interface connection:

- ✓ Check whether the internal and external thread interfaces are clean and not damaged before installation. Confirm that the external thread interface is fastened;
- ✓ If necessary, screw the inner thread interface into the cylinder valve with a specified torque of 20 to 30 nm;
- ✓ Push the external thread connector into the inner cylinder valve. The handle rotates counterclockwise for about 45, the "kada" sound is heard, and the bottle valve is successfully connected to the pressure reducer.

(13) Hold the handwheel and pull it up to confirm that the cylinder is fully fixed.

**Attention!**

If the belt is too tight during the tightening, readjust the length of the belt. If the cylinder belt is too loose, readjust the length of the belt on the cylinder belt buckle. If the cylinder feels loose, check the latch engagement with the slot on the strap. Ensure that the latch is fully tightened. Do not use the SCBA if the cylinder is not firmly fixed in the bracket.

When the cylinder valve is connected with the pressure reducer, install it manually and tighten it without any tools.

Do not use too large force to fasten the belt lock to prevent the belt from being too tight and damaging the cylinder belt lock.

**Warning!**

When replacing the cylinder, please pay attention to whether the maximum working pressure is the same, and the cylinder with the same maximum working pressure must be replaced. When SCBA, bottle valve must be closed (including empty bottle).

Inflatable air cylinder

The replaced cylinders are inspected and inflated by an authorized professional.

**Warning!**

The inflation pressure shall not exceed the rated working pressure of the cylinder.

The air cylinder inflation must be filled to the filling unit registered by the boiler and pressure vessel safety supervision agency of the provincial quality and technical supervision department, and the company shall not bear any responsibility for the consequences caused by the illegal inflation.

7 Tempus utile



Warning!

The product operability must be confirmed before using the product. Equipment shall not be used under the following circumstances:

- Functional test was unsuccessful;
- The equipment is damaged;
- Proper repair / maintenance is not performed;
- Or no original MTS spare parts are used.

Please consider the following factors that may affect the duration or service life:

- Physical activity amount of the users;
- The physical condition of the user;
- The extent to which agitation, fear, or other emotional factors contribute to the increased respiratory frequency in the users;
- Level of user training or experience with this device or similar device;
- Whether the cylinder is full;
- Conditional status of the SCBA.

Leave the work area immediately under the following situations:

- Breathing becomes difficult;
- Generates dizziness or other distress;
- You eat or smell the pollutants;
- You feel a sore nose or throat;
- Use the equipment by instructions or training, but the equipment does not operate.

It is strictly prohibited to use the back equipment and bracket components as vertical lifting equipment.

It is strictly prohibited to use this equipment as a scuba diving equipment. This causes air quickly and is very damaging or life-threatening.

If there is discoloration, cracking, foaming, cracking, or other deterioration that is observed, immediately return to a safe environment .

Due to possible high temperature conditions during fire extinguishing operations, detailed appearance and functional tests of each SCBA after each use to ensure that there are no any potential adverse effects in use.

Wrong operation or failure to follow this warning may result in serious injury or death.

Check the pressure on the chest during use.

When the red area of the meter on the pressure gauge.

The low-pressure alarm sends a signal when the cylinder pressure drops below these approx values:

- 1) When the cylinder pressure of 300Bar evaluates the safe evacuation time is 100Bar. If it is lower than 55Bar \pm 5Bar, please return to the safe environment immediately;
- 2) SCBA air leak (supply air without inhalation);
- 3) The low-voltage alarm device gives an alarm;
- 4) Immediately return to the non-hazardous environment when the pressure alarm device indicates the cylinder pressure remaining about 10Bar;
- 5) If airflow decreases in SCBA: immediately check the pressure gauge value and open the discharge valve to force air supply. In the above situation, please return to the safe environment immediately.
- 6) If the primary low pressure alarm device is not alerted, deactivate the respirator device. Verify that the MTS training-certified maintenance technician has corrected all issues before reusing the equipment.

7.1 Freezing environment use

If frozen, the moisture can cause problems with the SCBA. But even if the surrounding air is above freezing, water causes freezing problems. The air from the cylinder flowing through the pressure reducer and the air supply valve drops rapidly from the cylinder pressure to near atmospheric pressure. This causes the air to swell and have a cooling effect. Although the ambient temperature may be higher than 0°C, the temperature within the air supply valve and pressure reducer may be lower.

- (1) Any water inside can become ice and block airflow. To prevent moisture from entering the air supply valve and reducing air, place the air supply valve into the air supply seat when not in use;
 - (2) When SCBA is away from high temperature, the beads will freeze on the air supply valve and pressure reducer surface. Ice will make the discharge valve knob can not be used normally. Before entering or re-entering the hazardous environment, please confirm that the air supply valve relief valve knob and pressure reducer are not frozen and operating normally;
 - (3) When replacing the SCBA cylinder, moisture will enter the cylinder from the cylinder valve or the connection nut. When replacing the cylinder, confirm that water or contaminants will not enter the equipment. Remove the ice from these accessories;
 - (4) Before installing the new cylinder, wipe the pressure reducer thread and the cylinder valve thread. Water will pollute and freeze the equipment;
 - (5) When cleaning SCBA, confirm that the water will not enter the air supply valve and pressure reducer;
 - (6) After cleaning and disinfection, thoroughly dry the air supply valve on the full cover and mask;
 - (7) Before storing the SCBA, ensure that the quick inflation protection cover (if any) is located.
-

8 Maintenance overhaul

SCBA must be cleaned before storage. If some parts of the SCBA are found to have been worn or damaged, they should be labeled and stored separately from the normal SCBA for repair by authorized personnel.

This device shall be regularly inspected and maintained by a well-trained professional technician. Testing and service records must be maintained. All MTS.

Repair and maintenance work must be performed only by authorized service centers or by the MTS. No changes to the unit or components may be invalid.

MTS, only responsible for the maintenance and repair operations performed by the MTS.

Check the entire SCBA after cleaning and disinfection.

**Warning!**

If the equipment does not meet any of the following inspection requirements, the use of the equipment must stop.

**Warning!**

Be careful not to damage the equipment during transportation and handling. If any faults or defects are found before use, it shall not be used under any circumstances.

The MTS recommends following the following maintenance intervals. The interval may be shortened if needed and considered. Follow the national laws and regulations!

If you have any doubts, please consult the MTS after-sales service personnel.

8.1 Clean, disinfect, and dry

Clean

After each use, the SCBA must be cleaned with warm water and (neutral PH) detergent. Attention must be paid to the detergent concentration and use time during cleaning.

For electronic devices such as HUD module, gently clean the surface with a soft brush or cleaning cloth and dry all surfaces after cleaning.

Disinfect

After cleaning, the air decompression system must be disinfected, with the appropriate concentration of disinfectant for a certain period of time. After disinfection, rinse with water to remove the residue of disinfection products.

Dry

After disinfection, cleaning and rinsing, SCBA must be dried before storage. Dry 2Bar clean air and do not use any other lubricating oil or moist air.

8.2 Maintenance of the full cover

Clean and disinfect the face mask

- 1) Wash with neutral soap or detergent (e. g. tableware detergent) in warm water (maximum temperature 43 c), and then rinse thoroughly with clean water. Dip sponge in 75% medical alcohol to wash the mask for disinfection.
- 2) After disinfection, wash the mask thoroughly with drinking water. The method is to flush with gentle water, then shake the mask, shake dry the residual water, and finally dry with a clean soft cloth, or with clean and dry, small pressure 2Bar breathing gently dry with air. Do not use unclean air when blowing dry.

Some cleaning and disinfection substances can cause damage or accelerated aging of empty pager parts. Therefore, only the recommended cleaning / disinfectants should be used. Residue detergent or disinfectant on the mask components that are not thoroughly cleaned and completely dry can cause damage to the mask components.



Warning!

Due to the electronic products on the comprehensive cover, it needs to be washed quickly for a long time, let alone to be soaked in water. After the cleaning, it is necessary to blow dry immediately to prevent the damage to the electronic components.

The mouth and nose cover is the built-in part of the mask, which does not need to be removed during cleaning and disinfection. If the mouth and nose cover is removed due to inspection, ensure that the correct slot of the valve body of the mask, and the valve piece on the mouth and nose cover is complete and without damage.

8.3 Maintenance of the air supply valve

Clean and disinfect the air supply valve

- 1) Wipe the obvious dirt on the outer surface of the air supply valve with sponge or soft cloth, and then scrub the air supply valve interface with 75% medical alcohol.
- 2) Check the inside of the supply valve from the outlet of the supply valve. If it has become dirty, please ask the authorized person to clean it up.

- 3) In order to make the air supply valve dry quickly, the clean air with the pressure not exceeding 2Bar can generally be blown dry. Do not use any other lubricating oil or moist air.
- 4) If the supply valve hose is disconnected from the MV pipe, reconnect. Open the bottle valve and the flush valve, blow away the residual water, and then close the emergency flush valve and the bottle valve.

Regularly apply a little silicone grease evenly on the sealing washer of the air supply valve to make the air supply valve more easily installed on the mask.

Check the air supply valve

The supply valve inspection does not mean a complete supply valve performance test. The performance of the air supply valve can be tested only using the maintenance detector designated by MTS. Before reuse, the user must conduct the operation inspection of the air supply valve according to the requirements of the operation manual.

- 1) Check and confirm that the air supply valve throttle switch (lower release button) has been completely pressed.
- 2) Check and confirm that the emergency discharge valve is closed.
- 3) Check and confirm that the air supply valve seal washer is not damaged. If the sealing washer is found to be damaged, the damaged sealing washer should be cleaned and reassembled-only the new sealing washer.
- 4) If the supply valve is removed from the mask for cleaning and disinfection, reinstall it.
- 5) Slowly open the bottle valve for at least one lap. If air is heard flowing from the supply valve, close the bottle valve and repeat steps 1) and 2). If air is still heard from the supply valve, close the bottle valve completely and mark for repair or replacement by authorized personnel.
- 6) Open the discharge valve and observe the vent port of the air supply valve. If small water droplets are found, the air supply valve has not dried yet.



Attention!

Apply a little silicone grease evenly on the sealing washer of the supply valve regularly to install the supply valve on the full cover easier.

If the air supply valve is immersed in the cleaning fluid, the liquid will enter the air channel of the air supply valve and thus damage the air supply valve. The air supply valve with internal cleaning requirements can not be used, but must be labeled and to be cleaned after disassembly by authorized personnel.

Storage empty empty that er not thoroughly dry can cause corrosion or other damage. See the low temperature operation section of this operation manual.

8.4 Maintenance of the compressed air bottles

- Visually check the appearance of the cylinder for any damage. Observe whether the cylinder carbon filament is broken. If it is broken, stop using it immediately and scrap it;
- Visually inspect the bottle valve and bottle valve pressure gauge without damage and abnormal deformation; if abnormal, it should be scrapped;
- The dirt on the surface of the cylinder can be cleaned with neutral detergent or clean water temperature exceeding 60°C.



Attention!

According to the state, the water pressure test for carbon fiber air cylinders should be conducted every three years. If the air cylinder test is not tested according to the national standards for more than three years, our company will not undertake any consequences caused thereby.

8.5 SCBA maintenance and maintenance

The SCBA is stored in an indoor environment with a temperature of 0 C~30 C. The room should be clean, dry and well ventilated to avoid the exposure of sunlight for a long time, and avoid thermal radiation and electromagnetic field. There should be no equipment that can produce ozone, electric spark or silent discharge nearby, and should not be stored together with oil, acid, alkali or other corrosive substances.

Before storing SCBA, it must be cleaned and dried. If some parts of SCBA have been worn or damaged, they should not be used again, stored separately, marked, and contact our after-sales department or authorized unit.

SCBA shall be stored in equipment box or special storage room and kept away from corrosive aires or liquids, room temperature 0°C ~30°C and relative humidity 40%~80%. When used less, it is recommended to apply talc powder on the rubber parts to prolong the service life of the empty pager.

If the empty pager is suspected that it is contaminated by dangerous objects, the contaminated parts must be marked and the maintenance personnel should replace it in time.

When the air pager and its spare parts need transportation, a reliable mechanical method should be used to fix the storage position or use it suitable for transportation and storage. During the storage and transportation of the empty pager and its spare parts, the packaging and storage of the empty pager should avoid causing damage to the vehicle or nearby personnel.

 **Warning!**

Do not drop the air cylinder or hit the valve knob. Even if the valve is only slightly open, the unsecured cylinder is bounced under its own pressure.

Misoperation may lead to serious injury or death.

- Do not store the SCBA or backup cylinders in areas adjacent to any material and environmental conditions that may expose or damage any part of the equipment, which will prevent the SCBA to operate as designed and permitted.
- Before storing the SCBA in the moving seat, confirm that the SCBA and the seat do not interfere. Confirm that the SCBA and air cylinders can be easily removed without damaging the components.
- If the SCBA is not used for a long time, please do not store the battery in the battery module (if any) in the SCBA for a long time. If you intend to use the SCBA, confirm that the battery in the electronic assembly (if any) has sufficient power.
- Do not store SCBAs with empty or unfilled cylinders. Always keep filled so that SCBA is ready for use.
- Confirm that the entire SCBA is clean and dry.
- Confirm that the back and full cap of SCBA are loose to maximum. Place the entire SCBA in a dedicated box or suitable storage for emergency use.
- To store the SCBA for a long time, remove the battery from all electronic components (if any) and the housing to prevent battery corrosion. Store the equipment in a cool, dry place.

Maintenance interval

Element	Work to be executed	Before using	After using	Yearly	Every 3 years
RHZK	Cleaning		✓	✓	
	Visual, Function, Power, Air Pressure and Density check	✓	✓	✓	
	Thorough overhaul				✓ Or after 600 hours of actual use
Cylinder fast interface	Cleaning		✓		
	lubricating			✓	
	User self-inspection	✓			

*Applicable national regulations must be observed.

*For frequently used self-contained respirator devices, the MTS recommends a thorough overhaul after approximately 600 hours of use.

*The cylinder quick connector must be lubricated after 300 connector connections or if necessary.

Appendix:

Packing listOrder number	Name of a part	Unit	Quantity	
1	self-contained positive pressure fire air breathing apparatus	Cover	1	
2	Electronic alarm device charger	Piece	1	
3	Spare parts bag	Piece	1	
4	Use and operation manual	Piece	1	
5	product qualification certificate	Piece	1	
6	Product quality tracking card	Piece	1	
7	Product test report	Piece	1	
8	Product code	Piece	1	

Spare parts bag parts table

Order number	Material code	Designation	Belong to the parts	Quantity
		O molding ring	air regulator	4
		Toolkit		1

Check the records form regularly

Device name: _____ Equipment number: _____ Cylinder number: _____

Inspection item	the situation of Check	Corrective measure	Testing time	Rummager
Full-face mask				
Air supply valve				
Pressure reducer				
High-pressure tube; Medium pressure tube				
Electronic pressure gauge				
Backplate module				
HUD				
Amplification communication equipment				
Compressed air cylinder				
Other				



Follow the WeChat
official account

MTS (NANJING) SAFETY TECHNOLOGY CO., LTD

Address: No. 1111, Fuying Road, Jiangning District, Nanjing, Jiangsu Province

Service Hotline: **4008-479-119**